

RuleMate® Bilge Pumps

500/800/1100 GPH – AUTOMATIC SUBMERSIBLE BILGE PUMPS

NEW

Our new bilge pumps provide ultimate pumping performance, which helps keep your bilge clear of nuisance water, building on the genuine Rule design.

The new RuleMate bilge pumps operate using an internal level sensor. When water reaches 2" (5cm), the pump will automatically activate, removing water from the bilge. When the water level reaches 3/8" (0.9cm) the pump will turn off until the water level rises again.

Bilges are not always clean and free from debris. If the level sensor becomes fouled by debris or contaminated water, RuleMate's unique back up feature will prevent the pump from entering a run-on condition, protecting the battery while maintaining automatic operation.

Our new designs include:

- **Higher Flow** – optimized impeller to provide up to 10% more flow at the same amperage
- **Auto Sense Intelligence** – integral water level sensor controls the pump automatically
- **Back Up Feature** – prevents continuous running if sensor is fouled by debris, pump reverts to 2.5 minute cycle mode
- **Smaller Footprint** – new RuleMate is 2/3 the size of existing model
- **Built-In Thermal Cut-Off (TCO)** – provides added protection for pump and vessel
- **Back Flow Prevention** – reduces the amount of water left over in the bilge, reducing odor and helping keep your bilge cleaner
- **Hidden Air Vents in the Body** – helps prevent air locking in challenging plumbing installations and helps with the check valve
- **Threaded Discharge** – easier installation, easier maintenance



The Rule brand builds on over 50 years of operational excellence and application expertise with a broad range of solutions for the marine industry.



ISO 8849 Marine (Electric bilge pumps)
ISO 8846 Marine (Ignition protection)



rule
a xylem brand

Rule...The world's most trusted pumps™

RuleMate Next Generation Bilge Pumps

Nominal GPH/LPH	Model No.	Volts	Amps @ 12V	Amps @ 13.6V	Check Valve	Hose Dia.	UPC
500 (1890)	RM500B	12 DC	1.8 (12V)	2.4 (13.6V)	YES	3/4" (19mm)	042237-106230
500 (1890)	RM500B-24	24 DC	1.0 (24V)	1.2 (27.2V)	YES	3/4" (19mm)	042237-106261
800 (3028)	RM800B	12 DC	3.0 (12V)	3.7 (13.6V)	YES	3/4" (19mm)	042237-106223
800 (3028)	RM800B-24	24 DC	1.6 (24V)	2.0 (27.2V)	YES	3/4" (19mm)	042237-106254
1100 (4164)	RM1100B	12 DC	3.8 (12V)	4.8 (13.6V)	YES	1" (25mm) AND 1-1/8" (29mm)	042237-106216
1100 (4164)	RM1100B-24	24 DC	2.1 (24V)	2.5 (27.2V)	YES	1" (25mm) AND 1-1/8" (29mm)	042237-106247



Check Valve Included

Weight

RuleMate 500	0.9 lbs (0.41kg)
RuleMate 800	0.9 lbs (0.41kg)
RuleMate 1100	1.05 lbs (0.48kg)

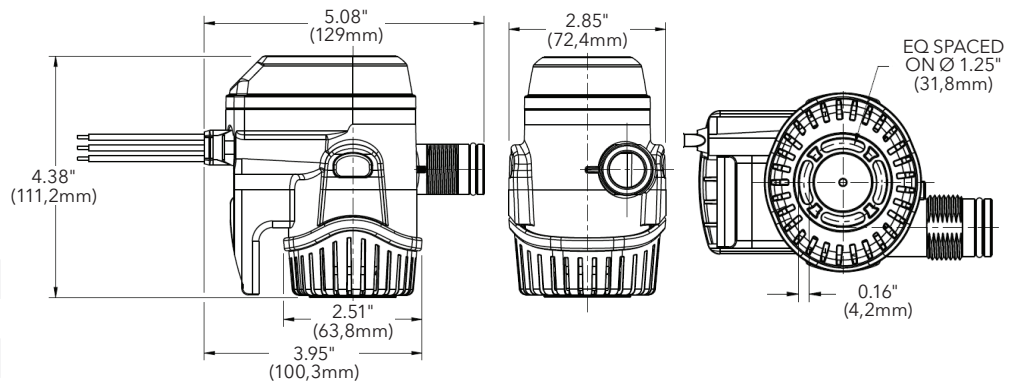

Performance at Rated Voltage (12 or 24 Volts)

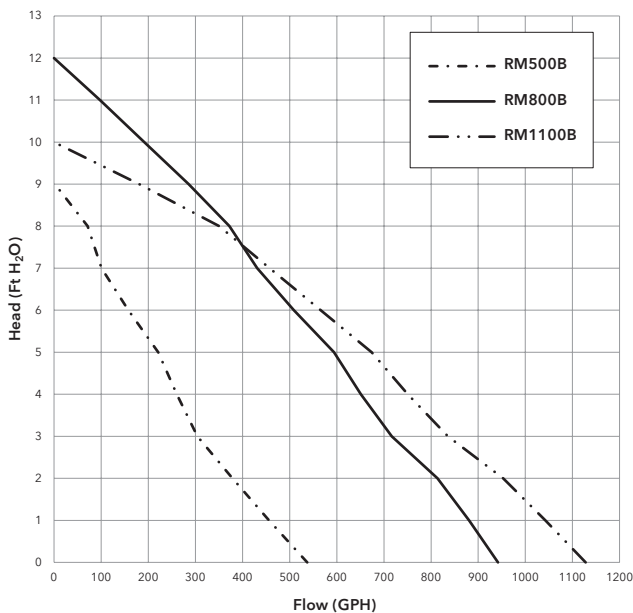

Spare Parts Description

Spare Parts Description	Model No.
500 3/4" (19mm) Barbed Port	1200R
500 3/4" (19mm) Barbed Port 90 Degree	1201R
500 1" (25mm) Barbed Port	1202R
800/1100 3/4" (19mm) Barbed Port 90 Degree	1203R
800/1100 3/4" (19mm) Barbed Port	1204R
800/1100 1" (25mm) Barbed Port 90 Degree	1205R
800/1100 1" (25mm) Barbed Port	1206R
800/1100 1-1/8" (29mm) Barbed Port 90 Degree	1207R
800/1100 1-1/8" (29mm) Barbed Port	1208R
500 3/4" (19mm) Check Valve	1220R
800/1100 3/4" (19mm) Check Valve	1221R
800/1100 1" (25mm) Check Valve	1222R
800/1100 1-1/8" (29mm) Check Valve	1223R



Barbed Ports



Strainer Base 1232R



Warranty: All products of the company are sold and all services of the company are offered subject to the company's warranty and terms and conditions of sale, copies of which will be furnished upon request. The information provided herein is for guidance only, it does not constitute a guarantee of the performance or specification of any individual product or component.

marine.xylem.com

USA

Xylem Inc.
100 Cummings Center
Suite 535N Beverly MA, 01915
Tel: (978) 281-0440
Fax: (978) 283-2619

UK

Xylem Inc.
Bingley Road, Hoddesdon
Hertfordshire EN11 0BU
Tel: +44 (0) 1992 450145
Fax: +44 (0) 1992 467132

GERMANY

Xylem Inc.
Oststrasse 28
22844 Norderstedt
Tel: +49-40-53 53 73-0
Fax: +49-40-53 53 73-11

PHILIPPINES

Xylem Inc.
12 Ring Road, LISP II
Brgy. Lamesa, Calamba City 4027
Tel: 63 (49) 5434341
Fax: 63 (49) 5456817

CHINA

Xylem Inc.
30/F Tower A, 100 Zunyi Road
Shanghai, China 200051
Tel: +86-21-2208-2888
Fax: +86-21-2208-2999

ITALY

Xylem Inc.
Via Tommaseo, 6 20059
Vimercate, Milano
Tel: +39 039 685 2323
Fax: +39 039 666 307